



SPARTA - DASH

15345SSB

12V LED LARGE FLAT BRICK LIGHT

Dash LED brick and step lights deliver sleek style, safety, and security in a powerful package. Available in small and large sizes, as well as flat and louvered versions, Dash features a cast 316 stainless steel front equipped with frosted glass for soft illumination.

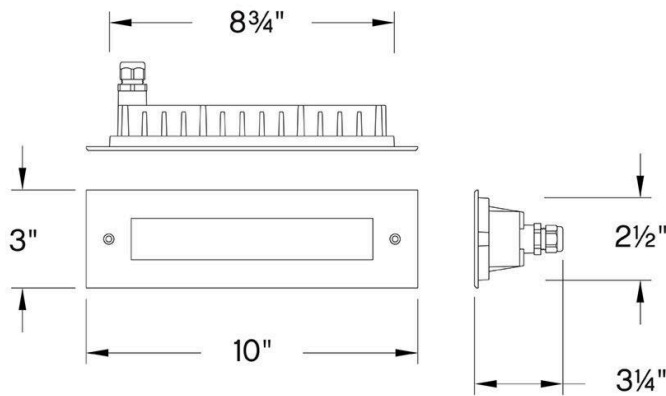

DETAILS	
FINISH:	Stainless Steel Black
MATERIAL:	Stainless Steel
GLASS:	Frosted Lens
DIMMABLE:	YES - WITH MLV ON TRANSFORMER PRIMARY

DIMENSIONS	
WIDTH:	10"
HEIGHT:	3"
DEPTH:	3.3
WEIGHT:	2.7lb

LIGHT SOURCE	
LIGHT SOURCE:	Integrated LED
LED NAME:	D15335/45
WATTAGE:	7w LED *Included
VOLTAGE:	12v
VOLT AMPS:	9.5
LUMENS:	175
CRI:	82
INCANDESCENT EQUIVALENCY:	1 x 40w
DIMMABLE:	YES - WITH MLV ON TRANSFORMER PRIMARY
TRANSFORMER REQUIRED:	Yes

MOUNTING	
LEAD WIRE:	1 X 72"

SHIPPING	
CARTON LENGTH:	12.6
CARTON WIDTH:	4.8
CARTON HEIGHT:	5
CARTON WEIGHT:	3



PRODUCT DETAILS:

- Suitable for use in wet (outdoor direct rain) locations as defined by NEC and CEC. Meets United States UL Underwriters Laboratories & CSA Canadian Standards Association Product Safety Standards
- Constructed with 316 stainless steel
- For more information on how to control your landscape lighting via the Hinkley Home Automation App, [click here](#).
- Bold lines and a clean, minimalist style complement contemporary architecture
- Rated for both indoor and outdoor use
- IP65 outdoor rated
- Mounting sleeve is required for installation
- LED integrated components carry a 10-year limited warranty