

TRELLIS

1439DZ

DOUBLE XL WALL MOUNT LANTERN WITH SCROLL

Trellis is a traditional European lantern design in an Aged Zinc finish with clear glass or Regency Bronze with clear seedy glass. The large scroll arm detail, cast loop finial and true rivet detail create a refined elegance.

DETAILS	
FINISH:	Aged Zinc
MATERIAL:	Aluminum
GLASS:	Clear
DIMMABLE:	YES, WITH DIMMABLE LAMP (NOT INCLUDED)

DIMENSIONS	
WIDTH:	16"
HEIGHT:	52"
WEIGHT:	31lb
BACK PLATE:	4.75"W X 20"H
EXTENSION:	24"
TOP TO OUTLET:	27.500000"

LIGHT SOURCE	
LIGHT SOURCE:	Socketed
WATTAGE:	4-5w Cand. LED, 60w Equiv.
VOLTAGE:	120v

SHIPPING	
CARTON LENGTH:	27
CARTON WIDTH:	20
CARTON HEIGHT:	56
CARTON WEIGHT:	43

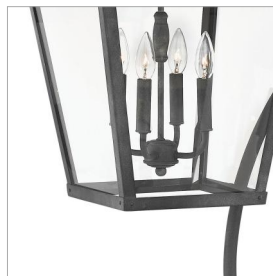
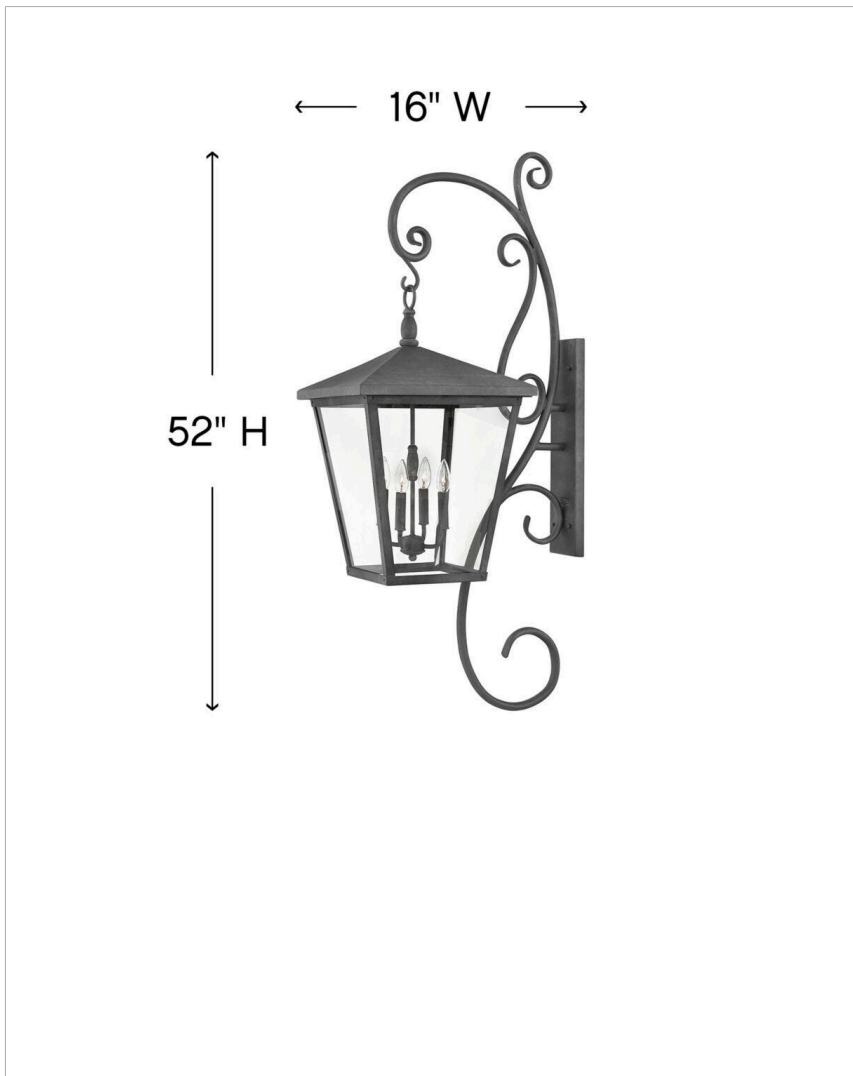

PRODUCT DETAILS:

- Our Estate Collections boast a breadth of fixtures defined by coordinating composition, enduring architecture, and time-honored craftsmanship, designed to meet the needs of expansive properties with extended outdoor living spaces. From the entrance of your driveway to the depths of your backyard, these collections provide cohesive design for stately exteriors.
- Suitable for use in wet (outdoor direct rain) locations as defined by NEC and CEC. Meets United States UL Underwriters Laboratories & CSA Canadian Standards Association Product Safety Standards
- Classic lines and heritage details complement traditional architecture
- 2-year finish warranty